

Meter Relays

239 Series Analogue Meter Relays



Series 239 meter relays combine a highly accurate indicator with High and Low set point relays. The relays can operate alarm and control devices when the monitored signal value moves outside the chosen set point limits shown by adjustable red index pointers.

A single compact case houses the unit which requires only the input signal and power supply thus saving space and installation time.

Features

- Monitors and controls any variable which can be converted in to an A.C. or D.C. signal
- Rugged shock and vibration resistant design
- Indicator, relays and power unit in one housing
- Control function continues if the indicator becomes damaged
- Stable electronic switching circuit does not use lamps, photocells, inductors or capacitors
- Taut band, fluid damped indicator
- Isolated input signal
- LED relay state indicators

Applications

- Voltage monitoring/ control current monitoring
- Overload alarm
- Battery monitoring/ charging
- Temperature indication
- Temperature control
- Load shedding
- Power factor correction
- Frequency monitoring
- Level control

Meter Relays

One relay, two setpoints

Upscale de-energised, down scale energised.
Typical applications: Liquid level control, load shedding & power factor correction.

One relay, one set point

Upscale energised, downscale de-energised.
Typical application: High alarm.

Two relays, two set points

Mid band de-energised, outside band energised.
Typical applications: High and Low alarm, High alarm plus shut down.

Two relays, two setpoints

Both upscale energised, downscale de-energised
Typical application: High alarm plus shutdown.

Two relays, two setpoints

High and low midband energised, outside band de-energised. No time delay.
Typical application: High alarm plus shutdown.

Two relays, two set points

Both upscale de-energised,downscale energised.
Typical application: Frequency monitoring.

One relay, one set point

Upscale de-energised, downscale energised.
Typical application: Low alarm.

Two relays, two set points

Midband de-energised, outside band energised.
Operates from from 2, 3 or 4 wire resistance temperature detector (RTD).
Typical application: Temperature indication / control.

Two relays, two set points

Midband de-energised, outside band energised.
Operates from thermocouple input. Cold junction compensation and thermocouple break protection are standard features.
Typical application: Temperature indication / control.

Product Code

239-300

239-301

239-302

239-303

239-304

239-305

239-307

239-30R

239-30T

Meter Relays

239 Series Analogue Meter Relays

Specification

Adjustments

Front panel comprises Set-point potentiometer(s), one per set-point
 Rear panel comprises Delay potentiometer(s), one per set-point

Measuring Input:

Note: All inputs are average sensing, but RMS calibrated

A.C. Voltage: 10V to 600V RMS (Sensitivity 1K Ω /V to 100K Ω /V, max. 2.5M Ω)
 A.C. Current: 1mA to 15A RMS (20mV drop)
 D.C. Voltage: 10mV to 600V RMS (Sensitivity 1K Ω /V to 100K Ω /V, max. 2.5M Ω Centre zero option up to 600/0/600V)
 D.C. Current: 100 μ A to 15A (20mV drop) Centre zero option up to 15/0/15 amps

Maximum continuous input voltage 1.2 x rating continuously (600V max.)
 Maximum continuous input current 1.2 x nominal (15A max.)
 Maximum short duration input current 6 x nominal for 6 seconds (30A max.)
 Frequency monitoring: 50Hz to 60Hz \pm 10%
 Burden <0.5VA

Damping time: 1 second
4" Scale: 100° deflection
Panel material: Ferrous or non-ferrous
Dielectric test: 2600V r.m.s. for 1 minute

Auxiliary supply

Aux. voltage A.C. 110, 120, 220, 230, 240, 277, 480V A.C. (\pm 20%)
 Aux. voltage D.C. 12, 24, 48, 120, or 135V maximum 156V D.C.
 Aux. frequency 50 to 60Hz \pm 10%
 Burden: <1.5W

Adjustments and Accuracy

Indicator accuracy Class 1.5
 Set-point range 98% of scale
 Set-point accuracy 1% of range
 Set-point hysteresis 1% of range
 Trip repeatability 0.5% of range

Relay tripping time <1 second
 Time delay 0 to 20 seconds, adjustable by potentiometer on rear panel **Option:** 0 to 10 seconds and 0 to 40 seconds
 Indication Single red LED, per set-point, to indicate trip condition

Outputs

Relays DPCO contacts rated 5A @ 250V A.C. 5A @ 30V D.C. resistive electrical life >10⁴ operations @ 5A, 250V A.C. contact class IIB (IEC 60255-0-20)

Relay logic Configurable to energise or de-energise on trip

Options

Relay latching When the measured signal reaches the set-point, the relay changes state and stays in this condition until the auxiliary supply is interrupted

Environmental and Mechanical

Ambient temperature reference range +15°C to +30°C nominal range of use 0°C to +60°C
 Storage temperature -20°C to +70°C
 Relative humidity <90%, non condensing
 Shock 15g/11ms (EN 60068-2-27)
 Bumping 40g/6ms (EN 60068-2-29)
 Vibration 10 to 300Hz (EN 60068-2-6)
 Protection class (BS EN 60529) Terminals to IP20 Enclosure to IP50

Enclosure

Flammability UL94V1
 Terminal capacities 1 to 4mm² solid or stranded conductors
 Weight <1kg

EU Directives

Low Voltage Directive 73/23/EEC amended by 93/68/EEC
 EMC Directive 89/336/EEC amended by 93/68/EEC
 CE Mark Directive 93/68/EEC

Options

CT	Calibrated at °C	LL	Low relays latch, remove auxiliary supply to reset
EB	Both relays latch, external switch to reset	MC	Clamp band fixing
EH	High relay latch, external switch to reset	NH	Hysteresis
EL	Low relay latch, external switch to reset	PD	Electrical heavily damped movements
FK	Finger knob setpoint adjusters	PG	Panel mounting gasket
KV	Sensitivity 100k/volt for A.C. input	RP	Retro-fit plate 237 meter relay
KW	Sensitivity 1k/volt for D.C. input	SL	Red line on instrument dial
KX	Sensitivity 100k/volt for D.C. input	SM	Customer logo on instrument dial (Note: one off setup charge may apply)
LB	Both relays latch, remove auxiliary supply to reset	SZ	Coloured band on instrument dial
LH	High relays latch, remove auxiliary supply to reset	TP	TPC-Time proportional control (proportional plus derivative control)

Meter Relays

239 Series Analogue Meter Relays

Dimensions and Panel cut-out

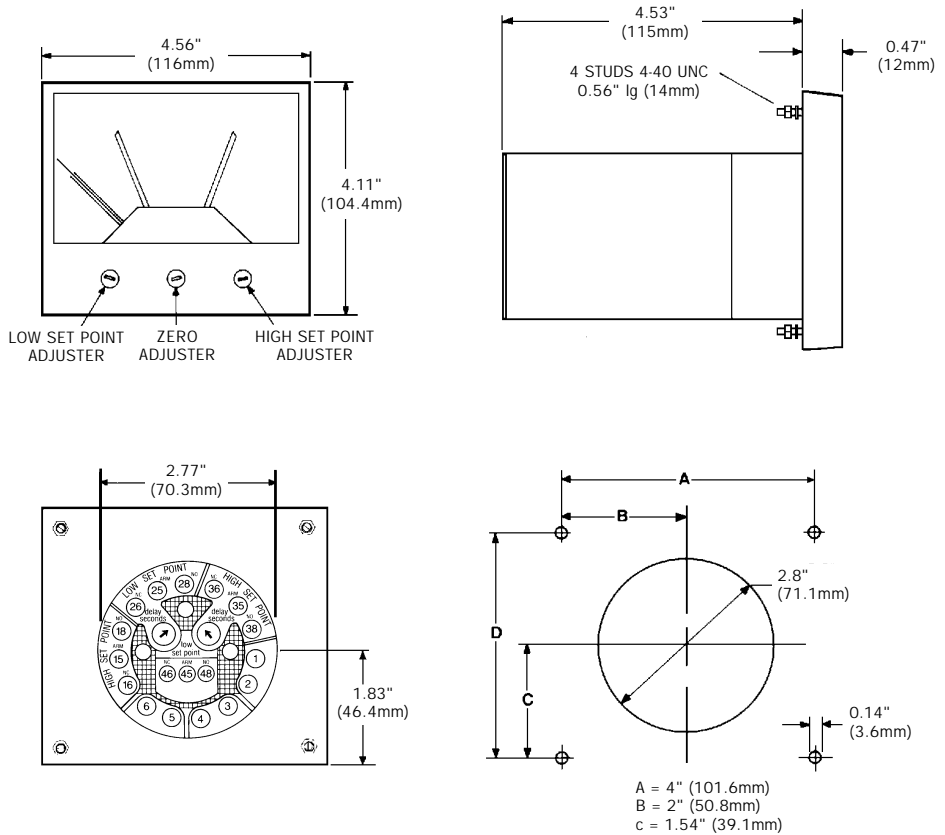

Connections

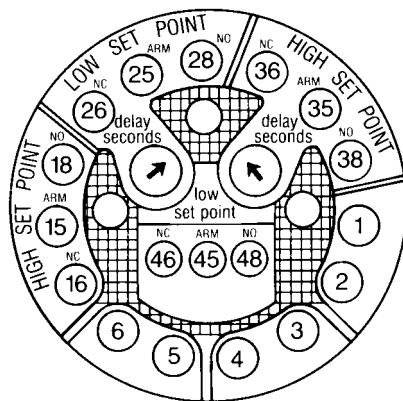

Measuring Input

Terminal

- 1 Meter N or -VE
- 2 Meter L or +VE
- 3, 4. RTD or Thermocouple input
5. Auxiliary supply neutral (-ve if D.C.)
6. Auxiliary supply live (+ve if D.C.)
4. Auxiliary supply tap for dual supply models